



KOOLTEC EQUIPMENT & PARTS INC

ISLAND FREEZER

MODEL : KT 18 (73" X34") END CAP

MODEL : KT 21 (83" X 34") SIDE UNIT

ISLAND FREEZER SPECIALLY DESIGNED FOR SELLING FROZEN ITEM DISPLAY



LIMITED WARRANTY
PARTS AND LABOR

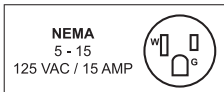

KOOLTEC EQUIPMENT & PARTS INC

kooltecnyc@gmail.com

www.KOOLTEC.us

929-451-7665

MODEL : KT 18 (73" X34") END CAP

TECHNICAL SPECIFICATION

ITEM NUMBER	1206
MODEL	KT18
POWER	0.56 kW
FREEZER CAPACITY	42OL
DOORS	2
NUMBER OF BASKETS	5
TEMPERATURE RANGE	≤ -18°C / ≤ -0.4°F
REFRIGERANT	R290
ELECTRICAL	110 V / 60 Hz / 1 Ph
WEIGHT	142kg / 264.5 lbs.
PACKAGING WEIGHT	140 kg / 313 lbs.
DIMENSIONS (WDH)	73.6" x 34.4" x 32.8"
PACKAGING DIMENSIONS	78" x39" x40"



END CAP



TECHNICAL DRAWING AND DIMENSIONS

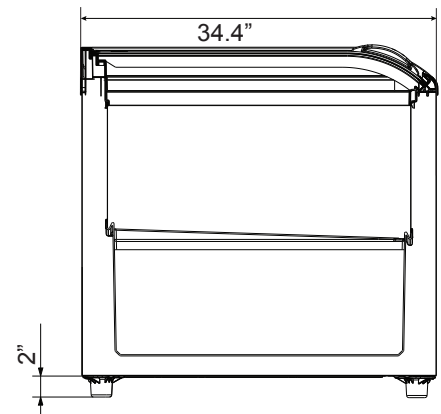
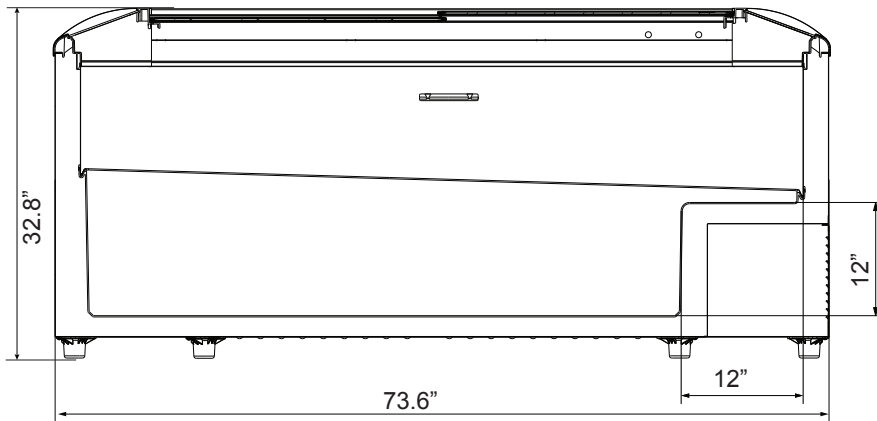

KOOLTEC EQUIPMENT & PARTS INC

kooltecnc@gmail.com

www.KOOLTEC.us

929-451-7665

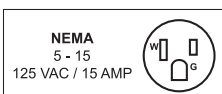

MODEL : KT 21(83" X 34") SIDE UNIT

TECHNICAL SPECIFICATION

ITEM NUMBER	1207
MODEL	KT 21
POWER	0.57 kW
FREEZER CAPACITY	500L
DOORS	2
NUMBER OF BASKETS	5
TEMPERATURE RANGE	≤ -18°C / ≤ -0.4°F
REFRIGERANT	R290
ELECTRICAL	110 V / 60 Hz / 1 Ph
WEIGHT	120 kg / 264.5 lbs.
PACKAGING WEIGHT	151 kg / 333 lbs.
DIMENSIONS (WDH)	83.2" x 34.4" x 32.8"
PACKAGING DIMENSIONS	87" x 39" x 40"



SIDE UNIT



TECHNICAL DRAWING AND DIMENSIONS

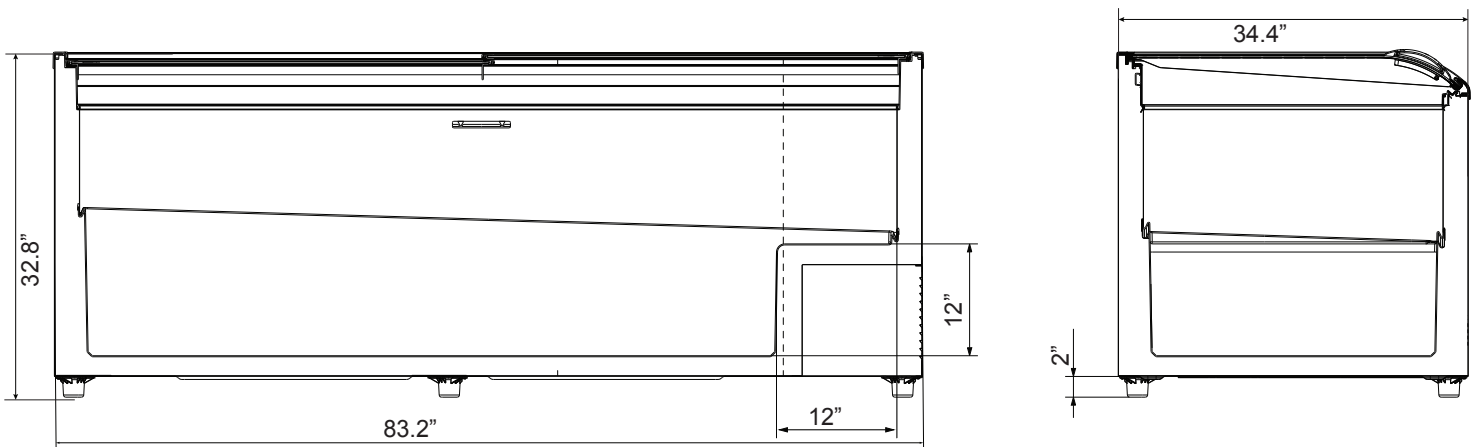

KOOLTEC EQUIPMENT & PARTS INC

kooltecnyc@gmail.com

www.KOOLTEC.us

929-451-7665

